

SYM	ECN NO	DATE	APPRVAL
△			

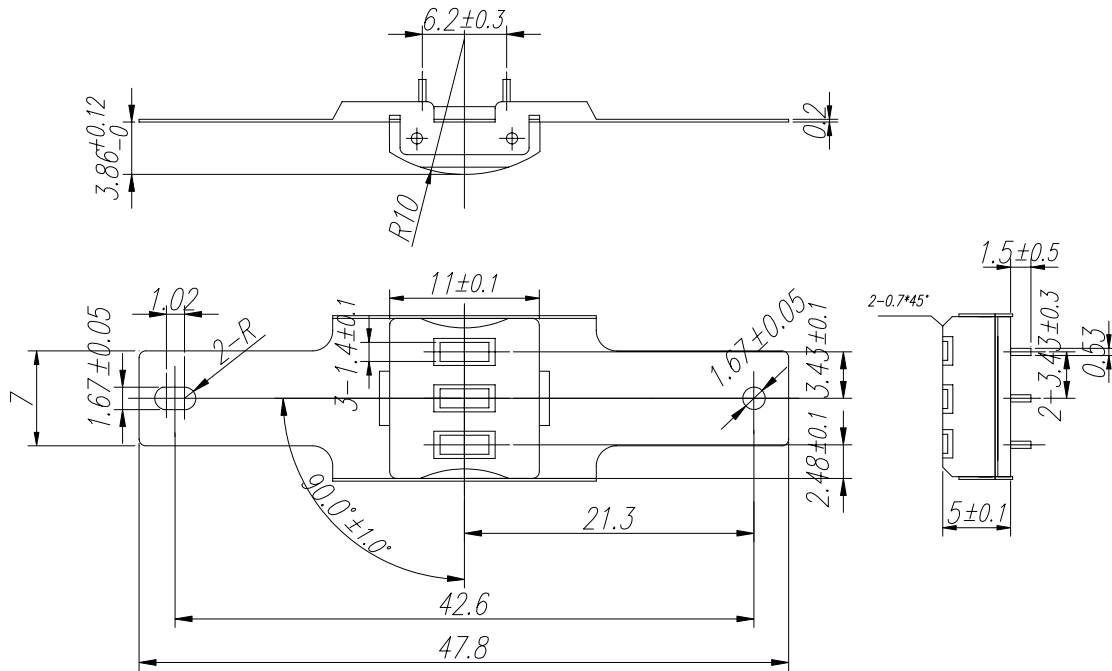

Specification

Inductance	mH	100±30%	1KHz	100 mA
DC Resistance	Ω	220±25%	DC	at 20°
Recording Density	BPI	210		
Tape Speed	IPS	7.5	Measuring Tape	
Read Output	mVp-p	36±25%	PM50-78	
Insulation R	MΩ	50	250V DC	
Core Earth	Ω	100 Max	100 mA	
Gap Length	μm	12.5±6		
Track Width	mm	1.4±0.1		
Head Life	Times	500,000Min		

UNLESS OTHERWISE NOTED:
 1) DIMENSIONS ARE IN MILLIMETERS
 2) TOLERANCES:
 .X ± .1
 .XX ± .05
 ANGLES ± 0°~30°

SCALE 2/1 MM REV A

CORE MATERIAL: PERMALLOY

MODEL SR33-6

DWG. NO 01030306

3 TRK READ HEAD

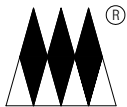

SUZHOU SPARK

DWG DGN CHK APP

ZHC

苏州星火磁电技术有限公司图纸