

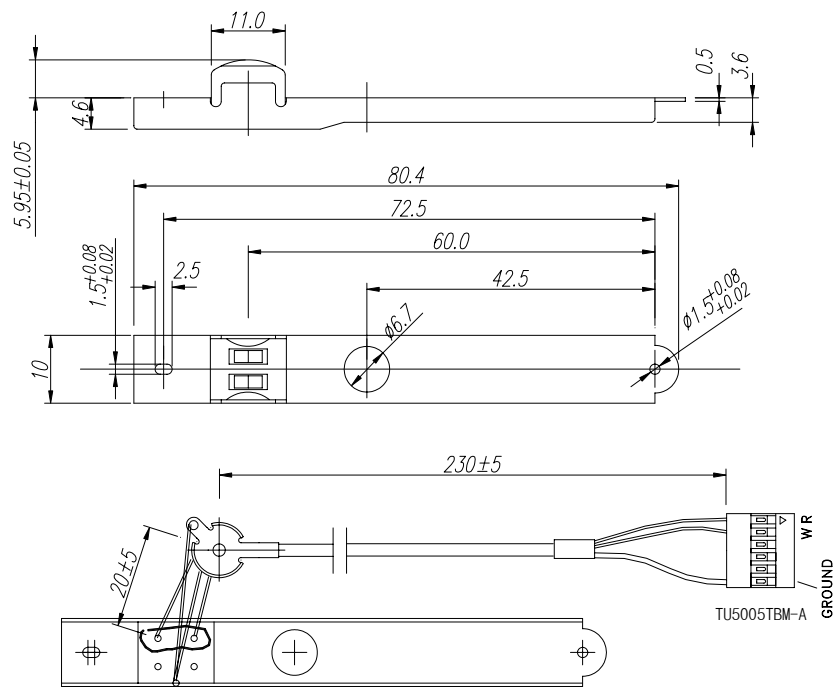

SYM	ECN NO	DATE	APPRVAL
△			



D.C RESISTANCE	280 ohm±20%
INDUCTANCE(1KHZ,300MV)	110 mH±25%
READ OUTPUT	25 mVp-p
RECORDING CURRENT	50 mA MAX
INSULATION(250V D.C)	50 MOHM(MIN)
EARTHING RESISTANCE	10 OHM(MAX)
RECORDING DENSITY	210 BPI
TAPE TYPE	3M-176
TAPE SPEED	7.5 IPS
CORE	sendust

MATERIAL		Q'TY	1	FINISH	BARREL	
TOLERANCE	X.X = ±0.1	SCALE	2/1	MM	REV	A
	X.XX = ±0.05	DATE	2003 03. 12			
DWG	DGN	CHK	APP	TITLE	DB-SR22S-022	
ZHC				MODEL	ATM-7	
 <b>SUZHOU SPARK</b>				DWG. NO	01211007	

## 苏州星火磁电技术有限公司图纸