

SYM	ECN NO	DATE	APPRVAL
△			

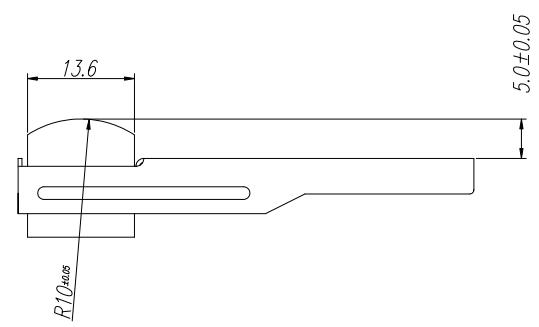
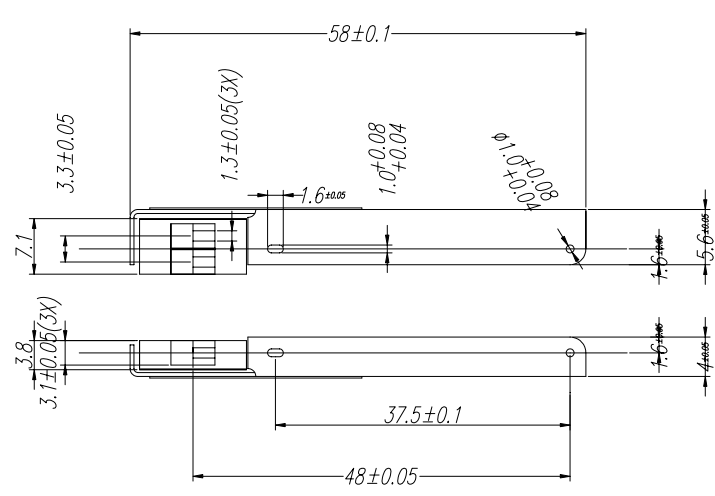
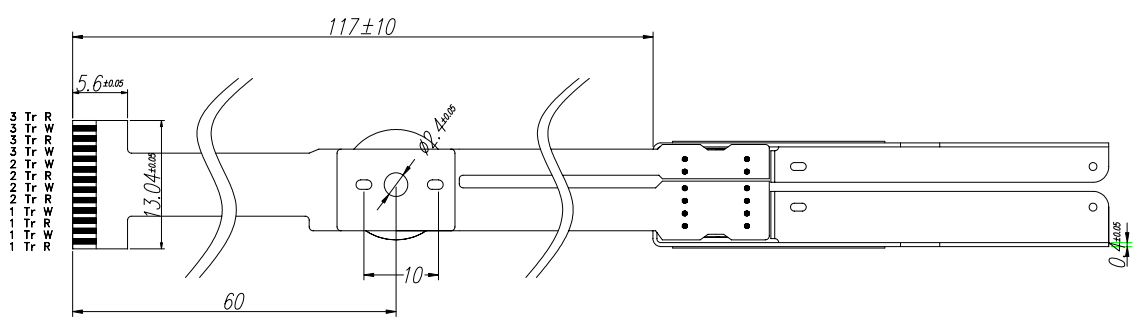
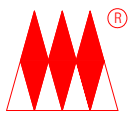

D.C RESISTANCE	R _{1,2}	200 ohm±20%
	R ₂	200 ohm±20%
	W _{1,2}	150 ohm±20%
INDUCTANCE(1KHZ,300MV)	R _{1,2}	150 mH±25%
	R ₂	150 mH±25%
	W _{1,2}	60 mH±25%
READ OUTPUT		25 mVp-p
RECORDING CURRENT		50 mA MAX
INSULATION(250V D.C)		50 MOHM(MIN)
EARTHING RESISTANCE		10 OHM(MAX)
RECORDING DENSITY		210 BPI
TAPE TYPE		3M-176
TAPE SPEED		7.5 IPS
CORE		sendust

MATERIAL		Q'TY		FINISH		BARREL	
		1					
TOLERANCE		SCALE		DATE			
X.X = ±0.1 X.XX = ±0.05 ANGLE =		2/1		2003 03. 12		MM REV A	
DWG	DGN	CHK	APP	TITLE			
ZHC				GKY0308100			
 SUZHOU SPARK				MODEL		ATM-3	
				DWG. NO		01211003	

苏州星火磁电技术有限公司图纸