

SYM	ECN NO	DATE	APPRVAL
△			

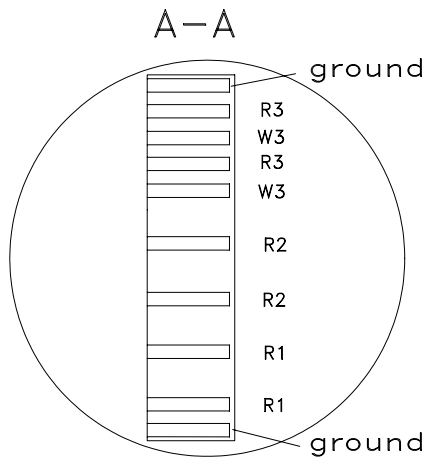
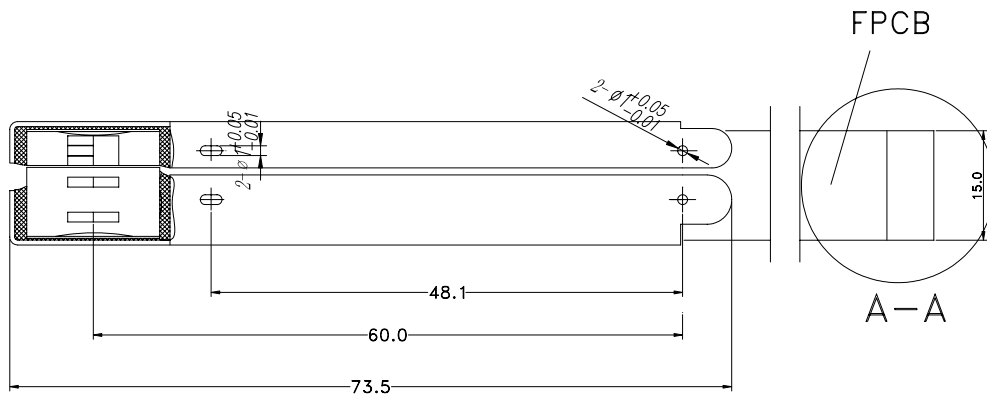
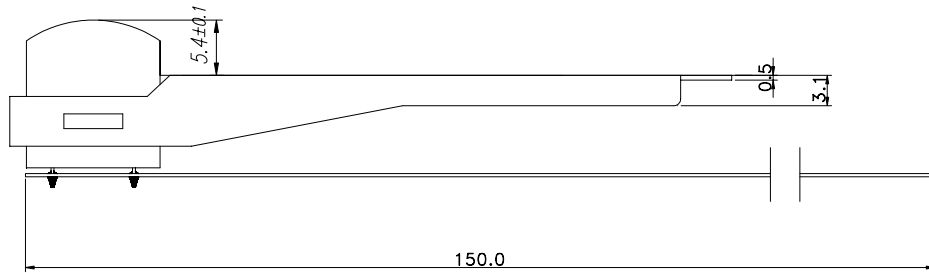
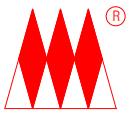

D.C RESISTANCE	R	110 OHM ± 20%
	W	48 OHM ± 20%
INDUCTANCE(1KHZ,300MV)	R	50 mH ± 25%
	W	5 mH ± 25%
READ OUTPUT	12 mVp-p	
RECORDING CURRENT	50 mA MAX	
INSULATION(250V D.C)	50 MOHM(MIN)	
EARTHING RESISTANCE	10 OHM(MAX)	
RECORDING DENSITY	210 BPI	
TAPE TYPE	3M-176	
TAPE SPEED	7.5 IPS	
CORE	sendust	

MATERIAL				Q'TY	1	FINISH		BARREL	
TOLERANCE X.X = ±0.1 X.XX = ±0.05 ANGLE =				SCALE	2/1	MM	REV	A	
				DATE	2003 03. 12				
DWG	DGN	CHK	APP	TITLE		NCR-S2R1RW-101-F2			
ZHC				MODEL		ATM-1			
 <b>SUZHOU SPARK</b>				DWG. NO		01211001			

苏州星火磁电技术有限公司图纸